

# ELLISSE PENDANT TRIPLE

*Federico Palazzari*

LED pendant provides diffused orientable light. Made from extruded aluminum in different finishes: matt lacquered white, black or gold, or polished in natural or gold. Equipped with an opal diffuser. The lamps are made using a proprietary extrusion coupling technology.

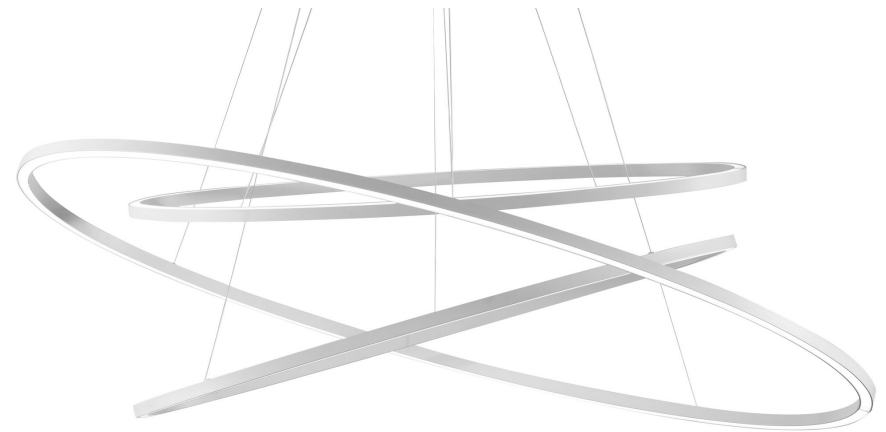

# LED 2700K

## LAMPING

Source	linear LED
Total power	70W
Emission	diffused orientable uplight(minor), diffused orientable downlight (major/minor)
Switching	dimnable 1-10V
Tension	120V
Color temperature	2700K
Luminous flux	1050+1630+1050lm (luminous output)
Typ CRI	85
Energy class	A+
IP class	20
Dimensions	53.2 x 27.6 x 8
Materials	Aluminum + PC
Notes	adjustable cable length 8.2' max, DALI version on request

## Codes

ELP LW2 57  
ELP LN2 57  
ELP LL2 57  
ELP LO2 57  
ELP LGW 57

## Structure

white  
black  
polished aluminum  
gold painted  
gold polished anodized

## PACKAGE

Package 01 Dimension: 31.5 x 59.1 x 5.9 inches / Gross weight: 16.5 lbs

## Certificazioni

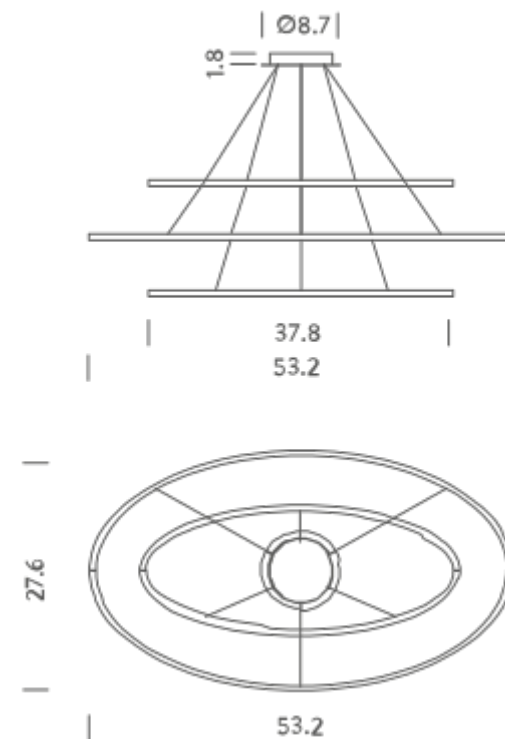

# LED 3000K

## LAMPING

Source	linear LED
Total power	70W
Emission	diffused orientable uplight(minor), diffused orientable downlight (major/minor)
Switching	dimnable 1-10V
Tension	120V
Color temperature	3000K
Luminous flux	1050+1630+1050lm (luminous output)
Typ CRI	85
Energy class	A+
IP class	20
Dimensions	53.2 x 27.6 x 8
Materials	Aluminum + PC
Notes	adjustable cable length 8.2' max, DALI version on request

## Codes

ELP LWW 57  
ELP LNW 57  
ELP LLW 57  
ELP LOW 57

## Structure

white  
black  
polished aluminum  
gold painted

## PACKAGE

Package 01 Dimension: 31.5 x 59.1 x 5.9 inches / Gross weight: 16.5 lbs

## Certificazioni

