

CROWN WALL

Jehs + Laub

A contemporary design icon reminiscent of ancient chandeliers: Crown, inspired by the shape of snowflakes, is characterised by a versatile design with a strong visual appeal, enhanced by a modular structure that allows countless possible combinations of colours and sizes.



CROWN 2

LAMPING

Source	G9
Total power	2x60W
Emission	diffused
Switching	dimnable, according to bulb
Tension	120V
IP class	20
Dimensions	10.2" x 7.1" x 6.3"
Materials	aluminum + glass
Notes	satin glass diffuser included, kit G9 LED NEMO available in the accessory section, bulb H max: 2.4', white RAL 9003, black RAL 9005, square cover plate included, bulbs included
Net lamp weight	3,1 lbs

Codes

- CRO HLW 31
- CRO HWW 31
- CRO HNW 31
- CRO HGW 31
- CRO HOW 31
- CRO HPW 31

Structure

- polished aluminium
- white
- black
- gold painted
- gold plated
- black plated

PACKAGE

Package 01 Dimension: 15"x21"x 6.3" inches / Gross weight: 4 lbs

Certificazioni

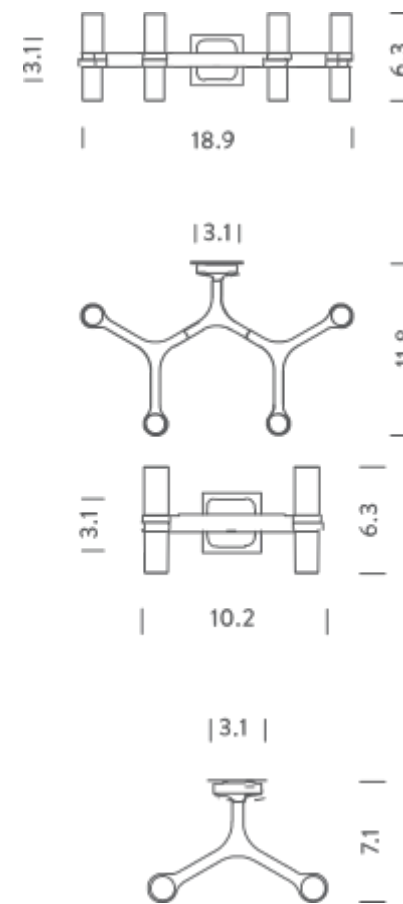

CROWN 4

LAMPING

Source	G9
Total power	4x60W
Emission	diffused
Switching	dimnable, according to bulb
Tension	120V
IP class	20
Dimensions	18.9" x 11.8" x 6.3"
Materials	aluminum + glass
Notes	satin glass diffuser included, kit G9 LED NEMO available in the accessory section, bulb H max: 2.4', white RAL 9003, black RAL 9005, square cover plate included, bulbs included
Net lamp weight	3,1 lbs

Codes

CRO HLW 32
CRO HWW 32
CRO HNW 32
CRO HGW 32
CRO HOW 32
CRO HPW 32

Structure

polished aluminium
white
black
gold painted
gold plated
black plated

PACKAGE

Package 01 Dimension: 15"x 21"x 6.3" inches / Gross weight: 4 lbs

Certificazioni

