

ELLISSE FLOOR/WALL

Federico Palazzari

Realised in various versions through an innovative technology developed by Nemo for coupling extrusions, Ellisse guarantees diffused direct and indirect lighting with the LED housed within the structure while remaining unobtrusive. The design is linear and contemporary, while an elegant black marble base becomes a pedestal for the floor version.



LED

LAMPING

Source	linear LED
Total power	66W
Emission	diffused
Switching	dimmable on cable
Tension	110-240V
Color temperature	2700K
Luminous flux	3450lm
Typ CRI	85
IP class	20
Materials	Aluminium
Notes	Cable length 5m Base and wall hanger sold separately
Accessories	Base, black marquinia marble Wall hanger, aluminium gold polished anodized
Net lamp weight	5 kg

Codes

ELP LNN 21
ELP LGN 21

Structure

black
gold polished anodized

PACKAGE

Package 01

Dimension: 15x80x150 cm / Gross weight: 7,5 kg

Certificazioni

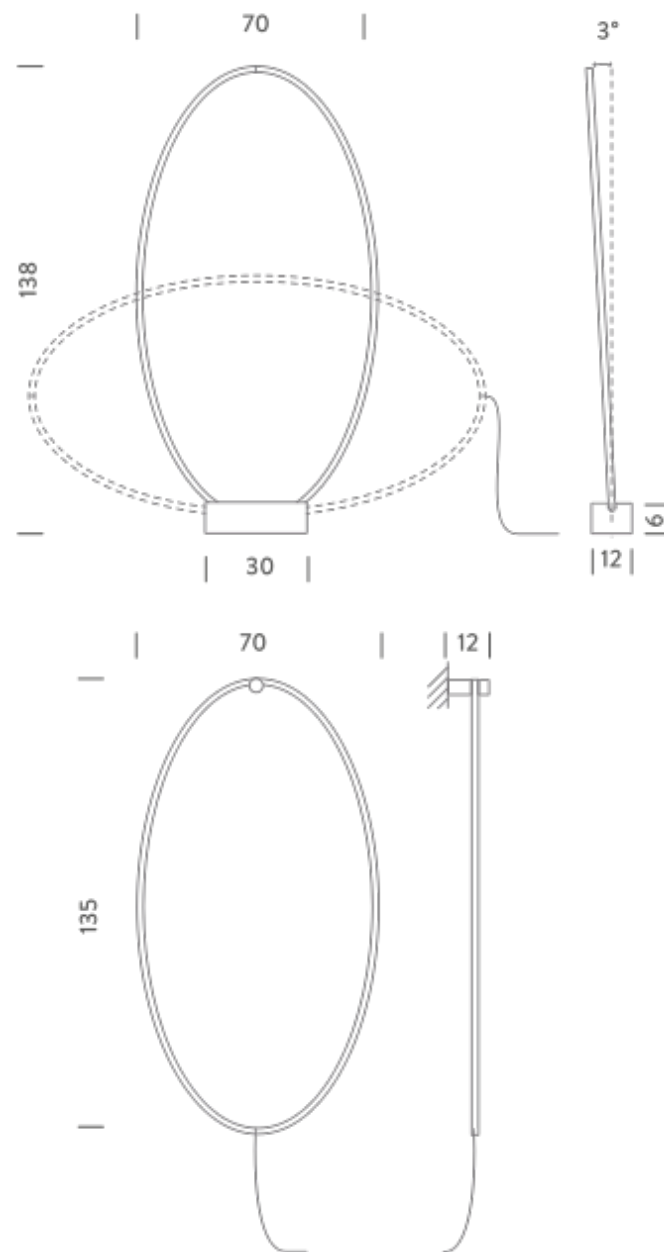

ACCESSORY:

base



wall hanger

