

ELLISSE PENDANT TRIPLE

Federico Palazzari

Collection de lampes de suspension et de lampadaires à suspension au sol disponibles dans différentes versions: major, minor, double, triple, méga et double mega, pour lumière diffuse directe ou indirecte. Fabriqué en aluminium extrudé en blanc mat, noir mat, aluminium brossé, or anodisé brillant ou or peint. Diffuseur en méthacrylate opale.

Ellisse est réalisé grâce à une technologie mise au point par Nemo pour le couplage des extrusions.

La version Major est également disponible dans le sol et au mur, avec un socle en marbre noir pour la version au sol et un accessoire de fixation au mur pour la version murale.

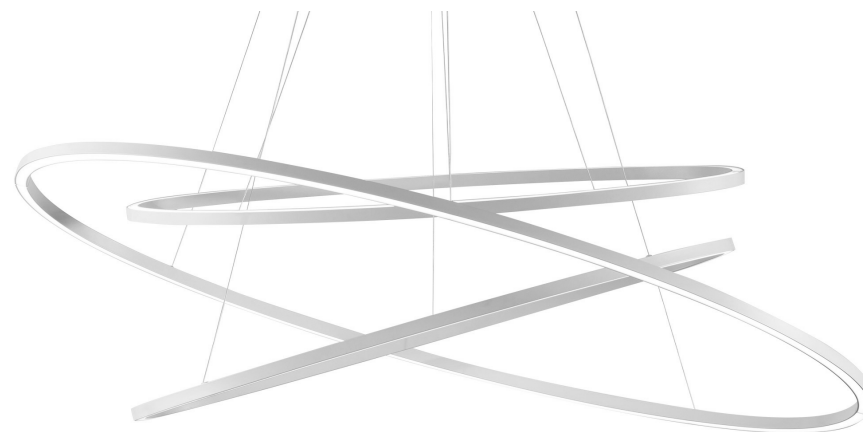

LED 2700K

LAMPING

Source	linear LED
Total power	100W
Emission	diffused orientable uplight(minor), diffused orientable downlight (major/minor)
Switching	dimnable 1-10V
Tension	110/240V
Color temperature	2700K
Luminous flux	1325+2050+1325lm
Typ CRI	85
Materials	Aluminium
Notes	adjustable cable length from 2,5 to 0,4 m, DALI version on request
Net lamp weight	5 kg

Codes

ELP LW2 57
ELP LN2 57
ELP LL2 57
ELP LO2 57
ELP LGW 57

Structure/Diffuser

white/white
black/white
polished aluminium/white
gold painted/white
gold polished anodized/white

PACKAGE

Package 01 Dimension: 80x150x15 cm / Gross weight: 7,5 kg

Certificazioni

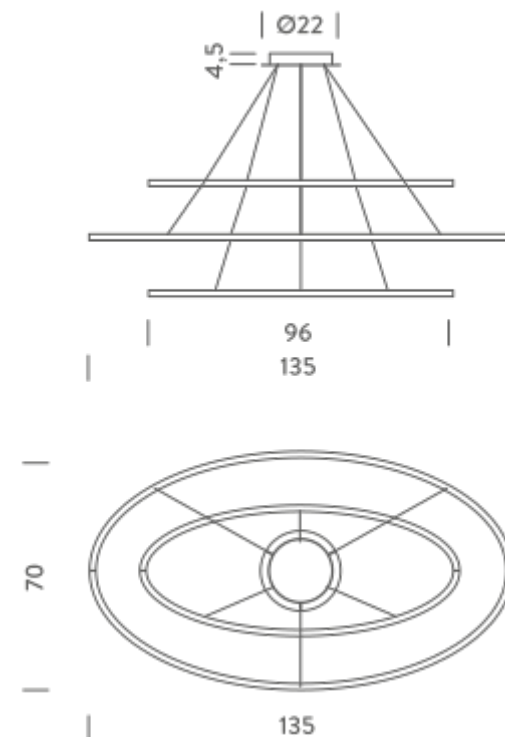

LED 3000K

LAMPING

Source	linear LED
Total power	100W
Emission	diffused orientable uplight(minor), diffused orientable downlight (major/minor)
Switching	dimnable 1-10V
Tension	110/240V
Color temperature	3000K
Luminous flux	1325+2050+1325lm
Typ CRI	85
Materials	Aluminium
Notes	adjustable cable length from 2,5 to 0,4 m, DALI version on request
Net lamp weight	5 kg

Codes

ELP LWW 57
ELP LNW 57
ELP LLW 57
ELP LOW 57

Structure/Diffuser

white/white
black/white
polished aluminium/white
gold painted/white

PACKAGE

Package 01 Dimension: 15x80x150 cm / Gross weight: 7,5 kg

Certificazioni

