

ILIUM PENDANT

Foster + Partners

Ilium se compose d'un corps cylindrique en forme de tonneau en verre transparent et d'un diffuseur interne en polymère opale pour un éclairage diffus à 360°.



77 E27 LED/HALO/FLUO

LAMPING

Source	E27 halo par20 bulb
Total power	50W
Emission	direct, diffused
Switching	dimnable according to bulb
Tension	230V
IP class	20
Materials	aluminium + glass
Notes	cabl length 3m
Net lamp weight	3,5 kg

Codes

ILI HHC 51

Structure/Diffuser

chrome/clear glass

PACKAGE

Package 01

Dimension: 22x22x98 cm / Gross weight: 4,2 kg

Certificazioni

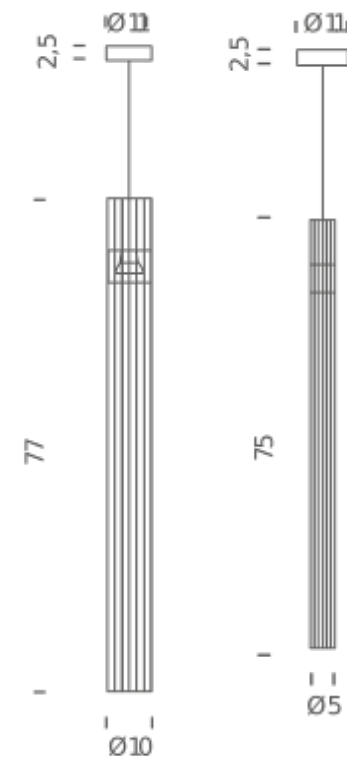

75 LED

LAMPING

Source	LED board
Total power	7W
Emission	direct/diffused
Tension	230V
Color temperature	3000K
Luminous flux	345lm
Typ CRI	85
IP class	20
Materials	aluminium + glass
Notes	cabl length 3m
Net lamp weight	3,5 kg

Codes

ILI LHC 51

Structure/Diffuser

chrome/clear glass

PACKAGE

Package 01

Dimension: 22x22x98 cm / Gross weight: 4,2 kg

Certificazioni

